



**Standard Metering Arrangement for Electric Vehicle
(EV) Charging Facilities
for
Car Parks of New / Existing
Building Developments and Village / Detached
House**

CLP POWER HONG KONG LIMITED

Date : March 2026

**Standard Metering Arrangement of
Electric Vehicle (EV) Charging Facilities for Car Parks of
New / Existing Building Developments and Village / Detached House**

1. Scope

This Guideline is intended to provide general technical references for standard metering arrangement to enable a developer / customer / contractor in the design of electrical installation for Electric Vehicle (“EV”) Charging Facilities to comply with CLP Power Hong Kong Limited (“CLP”) requirements only. EV charger equipment and facilities shall be designed, installed, maintained and operated in accordance with Electricity Ordinance and other statutory requirements, applicable standards, regulations and guidelines.

This Guideline should be read in conjunction with CLP’s Supply Rules, CLP’s “Guide to Supply and Metering Arrangement on Customer's Internal Distribution System”, “Code of Practice for the Electricity (Wiring) Regulations”, “Technical Guidelines on Charging Facilities for Electric Vehicles” and “Design Guidelines for Electric Vehicle Charging-enabling Infrastructure under the EV-charging at home Subsidy Scheme (EHSS)” published by the Electrical and Mechanical Services Department (“EMSD”) and Environmental Protection Department (“EPD”).

2. General Requirements

- 2.1 EV Charging Facilities shall mean fixed electrical installations on the customer side provided for EV charging including but not limited to switchboards, distribution boards, cabling, conduits and trunkings, electrical protective device, power quality equipment, and charging sockets or plugs, EV charger or kiosk and associated systems and equipment such as charging control system, payment system and communication equipment etc.
- 2.2 EV Charging Facilities shall be supplied and metered appropriately as per CLP's requirements.
- 2.3 EV Charging Facilities shall reasonably practicable be metered separately from non-EV charging loads. The electricity meter of EV Charging Facilities shall not be used for non-EV charging loads.
- 2.4 For private EV charging of both new / existing residential building, individual metering shall be adopted for each private parking space with EV charging facility (Fig. 1).
- 2.5 For private EV charging of corporate company, a single metering arrangement shall be adopted for a group of parking spaces with EV charging facilities (Fig. 1).

- 2.6 For public EV charging (e.g. public transport interchange, shopping mall, etc.), a single metering arrangement shall be adopted for a group of parking spaces with EV charging facility (Fig. 1).
- 2.7 For private EV charging of village / detached house, a single metering arrangement shall be adopted for EV charging facilities of each registered customers and / or owners of the house. (Fig. 5).
- 2.8 Adequate space shall be reserved to accommodate the meters and associated metering equipment and current transformers (if any) in switch room / meter room (including cable duct & closet) / meter cubicle. The position and spacing of meters shall allow easy and convenient access for meter reading and maintenance. The meter position shall be readily accessible from communal area at all times and must not be obstructed with reference to the CLP's "Guide to Supply and Metering Arrangement on Customer's Internal Distribution System" and "Supply Rules".
- 2.9 Metering arrangement for EV Charging Facilities shall comply with the requirements stated in "[Guide to Supply and Metering Arrangement on Customer's Internal Distribution System](#)" which is available at CLP website (www.clp.com.hk).
- 2.10 For new or existing building development and a fixed electricity installation of EV charging facilities with estimated demand of 400A low voltage or above; or multi-customer premises, developer / customer / contractor shall submit design schematic of electrical installation for Electric Vehicle (EV) facilities / infrastructure to CLP for vetting prior to commence installation. Upon completion of EV Charger facilities / infrastructure, foresaid parties shall seek CLP for inspection.
- 2.11 EV charger(s) should be metered by a separate meter from an unmetered source. Sub-meter is generally not accepted.
- 2.12 The location of the meters and collector shall have strong 4G telecommunication signal of mobile operators engaged by CLP (e.g. CSL, CMHK and 3 HK) as far as practical.
- 2.13 Even distribution of electrical loads for EV charging facilities among three phases is preferred.
- 2.14 EV charging facilities shall generally be supplied from electrical equipment located on the same floor. CLP meters for individual parking spaces shall be installed inside a meter room or within a meter cubicle at each car park level.
- 2.15 Customers may apply through submission to CLP for recovering charges of providing EV charging services. This is restricted for EV charging services only and requires prior approval through specified application form. Application details can be referred to CLP website at ([Application for approval to recover the charges for providing charging services for EV](#))

3. Metering Arrangement for New Building Developments

- 3.1 The metering arrangement mentioned in this section is applicable for new building developments (e.g. residential, commercial, industrial and municipal buildings). The metering arrangement for existing building shall refer to section 4. The metering arrangement for village house / detached house shall refer to section 5.
- 3.2 The meter(s) should be installed inside meter room(s) as agreed by CLP.
- 3.3 EV Charging Facilities Supply Zone Layout, EV Charging Facilities Numbering and Location Drawing and LV Schematic Diagram for the power supply arrangement to EV Charging Facilities shall be posted inside the meter room. Proper label should be provided for each meter to indicate its connection to the respective EV Charging Facilities shown on the numbering and location drawing (Fig. 3).
- 3.4 Power supply for smart meter collectors shall be provided and installed by customer at no cost to CLP. (Detailed arrangement refers to Detail “A”)

4. Metering Arrangement for Existing Building Developments

- 4.1 For existing buildings under EV-charging at home Subsidy Scheme (i.e. EHSS), sub-meter arrangement is not accepted. For other existing buildings (i.e. non-EHSS), if separate metering with un-metered source is technically or practically infeasible, then sub-meter arrangement may be considered with prior approval from CLP.
- 4.2 For the sake of safety and ease of future operation and maintenance, all meters for EV charging facilities should be housed inside a meter room as far as practicable (Fig. 2 and Detail “A” – Meter Room Option).
- 4.3 To provide flexibility for private parking space owned by individual customer, if there are unresolved site constraints such that the existing meter room(s) is/are unable to house the new additional meters for EV charging facilities, separate wall-mounted Meter Cubicle Option can be adopted, subject to the following conditions with prior agreement from CLP:
 - 4.3.1 A separate wall-mounted Meter Cubicle shall be installed at a suitable location with prior approval from CLP within Carpark (Fig. 2 and Detail “B” - Separate Wall-mounted Meter Cubicle Option).

- 4.3.2 EV Charging Facilities Supply Zone Layout (Fig. 4) shall be posted outside the Meter Cubicle.
- 4.3.3 EV Charging Facilities Numbering and Location Drawing and LV Schematic Diagram for the power supply arrangement to EV Charging Facilities should be posted outside the Meter Cubicle. Durable label should be provided for each meter to indicate its connection to the respective EV Charging Facilities shown on the numbering and location drawing (Fig. 3).
- 4.3.4 Safety poles with contrast colour marking (e.g. yellow/black) shall be erected with a minimum of 1,000 mm clearance in front of the Meter Cubicle to provide clear demarcation for the working area (Detail “B”- Separate Wall-mounted Meter Cubicle Option). Location of safety poles should be coordinated with meter cubicle so that the safety poles would not lead obstacle to working personnel for access.
- 4.3.5 For all large additional and alternation of installation in existing residential, industrial and commercial building (e.g. EHSS), the provision of power supply for smart meter collectors shall be provided and installed at no cost to CLP. (Detailed arrangement refers to Detail “A” and Detail “B”)
- 4.3.6 For other individual EV application (e.g. non-EHSS), power supply for smart meter collectors shall be provided and installed by customer at no cost to CLP upon requested by CLP.

5. Village House / Detached House

5.1 Supply and Metering Arrangement

- 5.1.1 Subject to the availability of sufficient spaces, separate meter for EV charger will be installed inside the concrete meter cubicle of residential revenue meters for existing or new house design. In case there is insufficient spaces, new adjacent meter cubicle will be installed (Fig 5) at the location with prior CLP’s agreement, which should be linked up with the concrete meter cubicle via cable ducts. While, the installation of new meter cubicle should be in compliance with all required regulations.

5.2 Prerequisite for Supply Application

- 5.2.1 The applicant needs to submit to CLP the written consent of all registered customers and / or owners of the house for the installation of the separated EV charging supply and meter cubicle, and associated equipment. The applicant should also comply with the terms and conditions of supply condition letter, which will be issued upon confirmation of EV charger power supply provision.

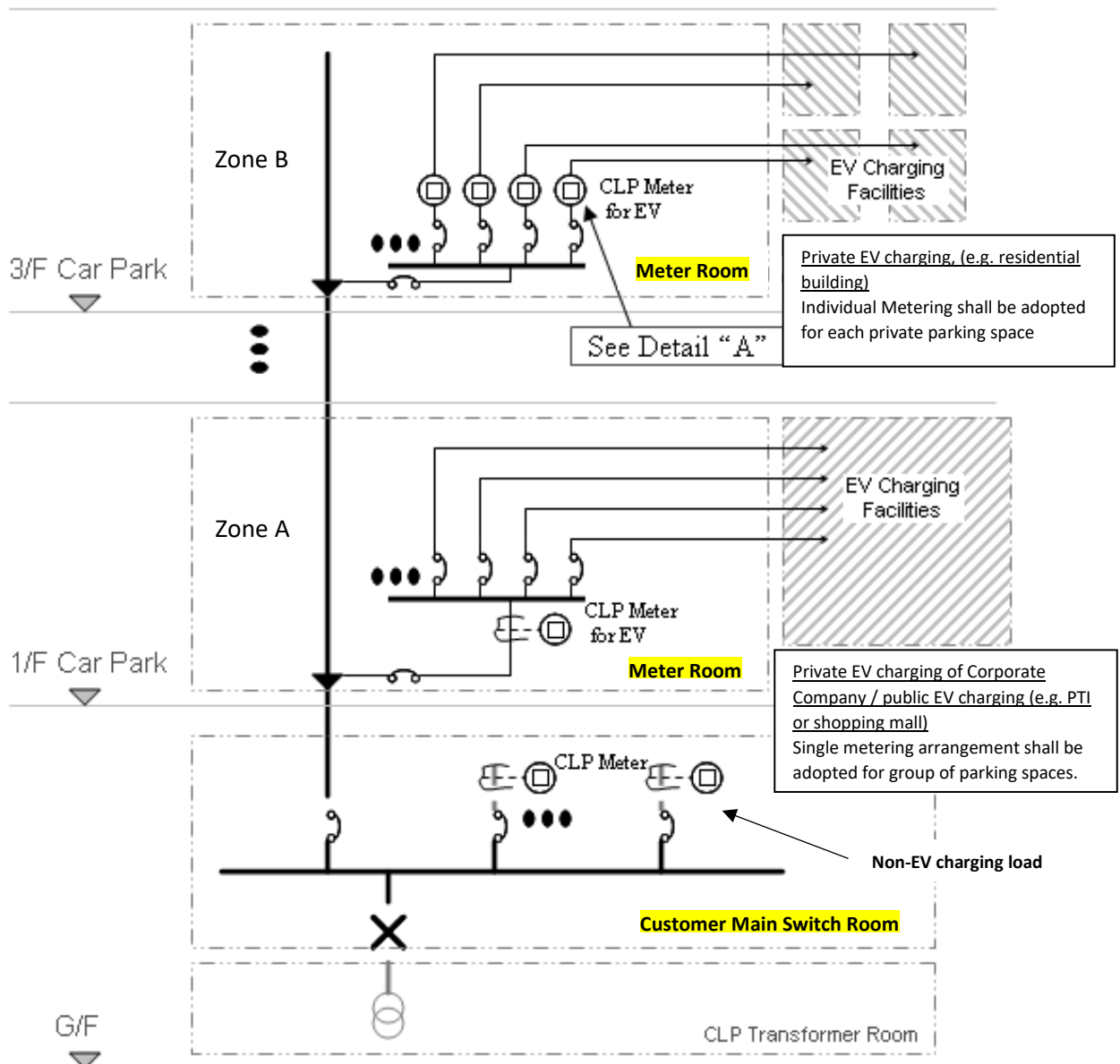
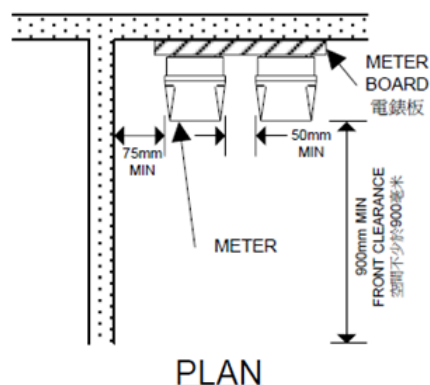
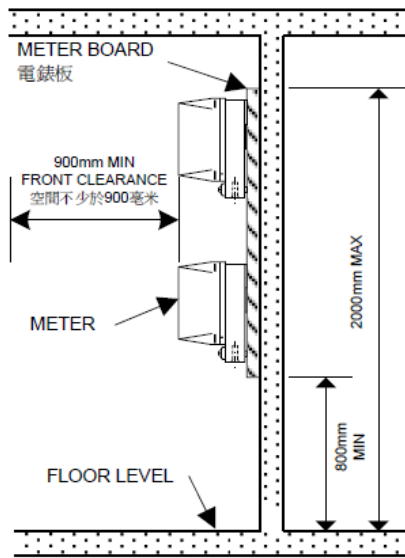
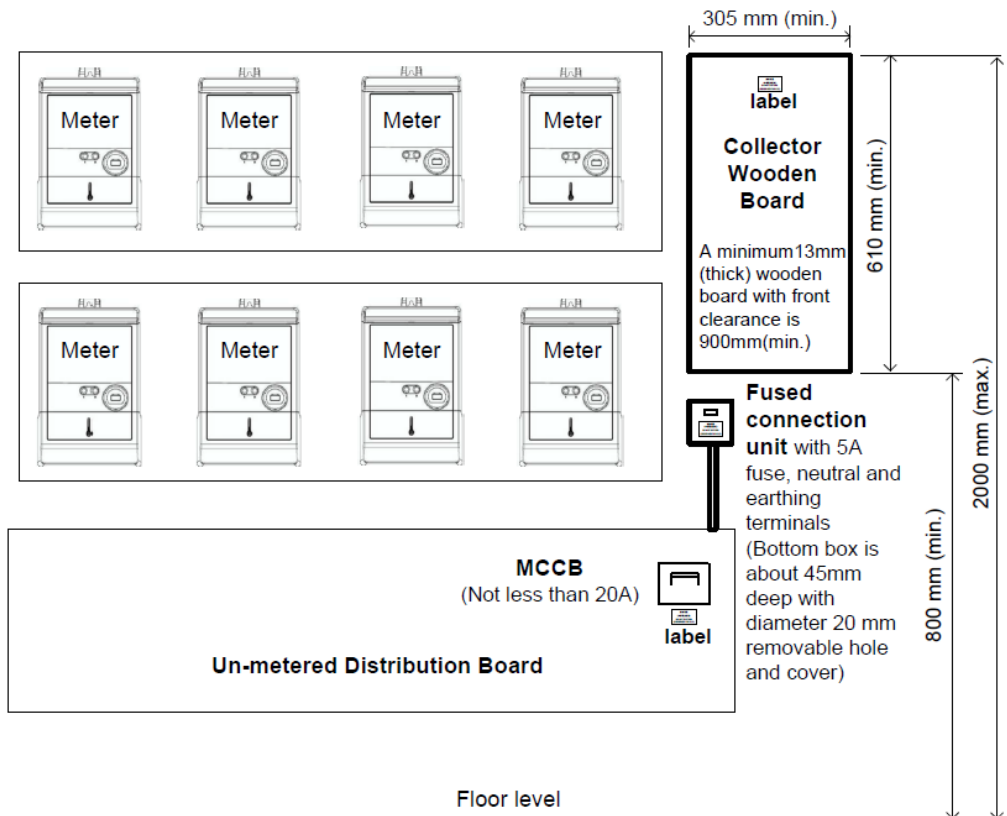

Fig. 1 – Typical metering arrangement for EV charger facilities of New Building Development



Facilities Locations & Wooden Board Requirements

A minimum 610mm(H) x 305mm(W) x 13mm(thick) wooden board, with front clearance of minimum 900mm, shall be provided for mounting CLP collector(s) in the meter room(s).

Beside of collector wooden board, a single phase fused connection unit for CLP collector shall be provided (fuse rated at 5A, unless otherwise specified). The circuit should be protected by a dedicated double poles MCCB if applicable of rating not less than 20A tapped off from un-metered distribution board in the same room/cubicle. Suitable neutral and earthing terminals should be provided in fused connection unit for CLP collector. The tapped off power supply location should be submitted to CLP Power for consent prior to the installation.

The location of the meters and collector is required to be able to receive strong telecommunication signal (e.g. 3G/4G)

Detail "A" – Meter Room Option for new and existing building

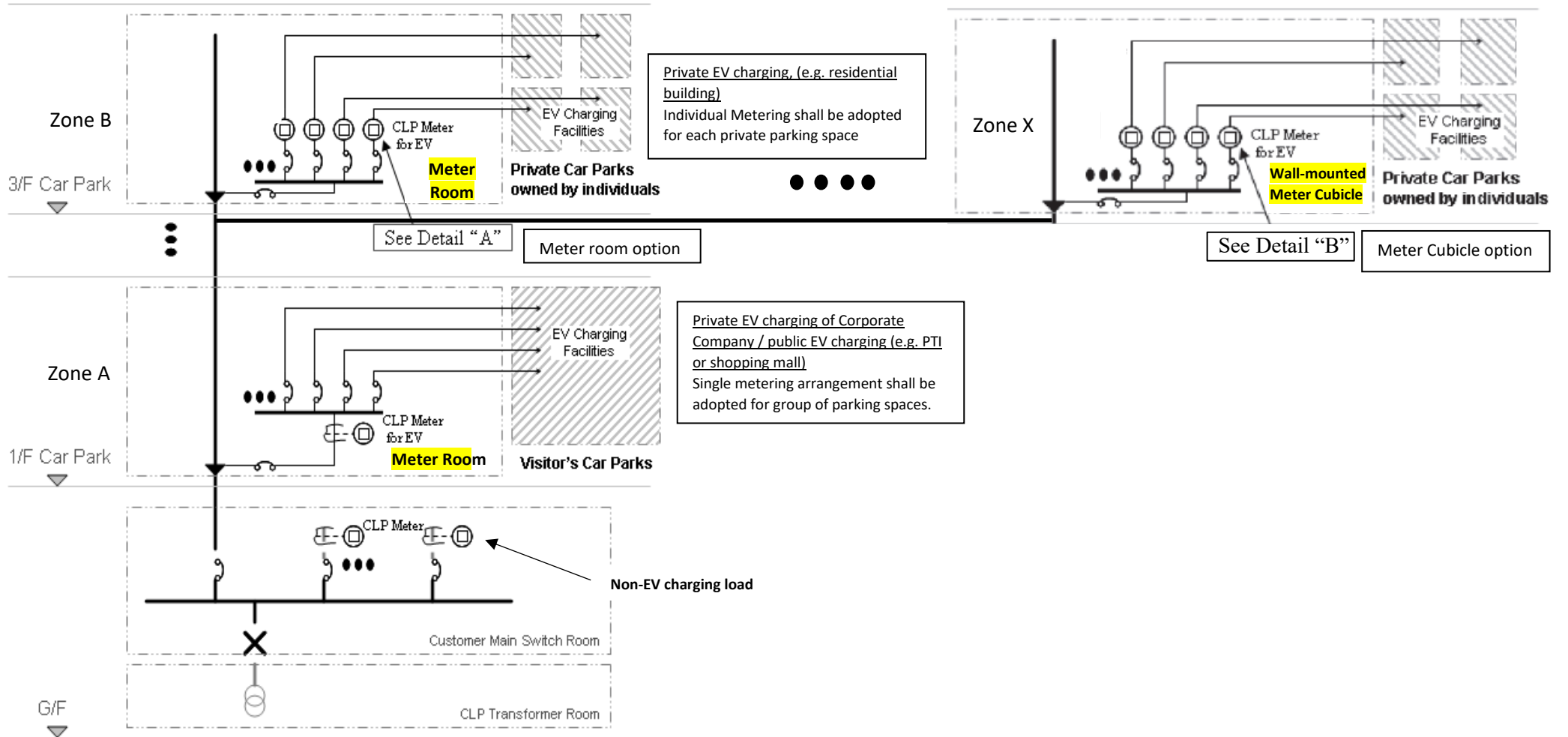
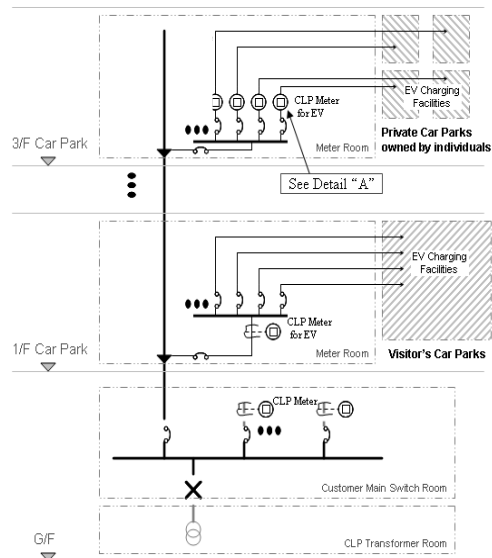

Fig. 2 – Typical metering arrangement for Existing Building Development



EV Charging Facilities Numbering and Location Drawing



LV Schematic Diagram



A1

A6

A9

A18

Proper Label to be posted inside the meter room with Indication of its Connection to Each EV Charging Facilities shown on the above Numbering & Location Drawing - Meter Room Option for new and existing building

Fig 3. Example of Drawing, Diagram and Label of meter room option

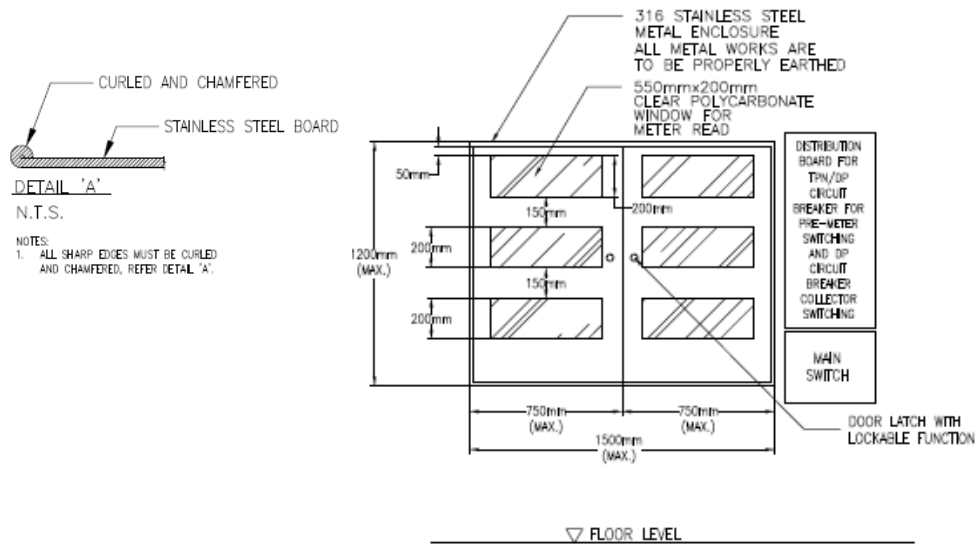

FRONT VIEW

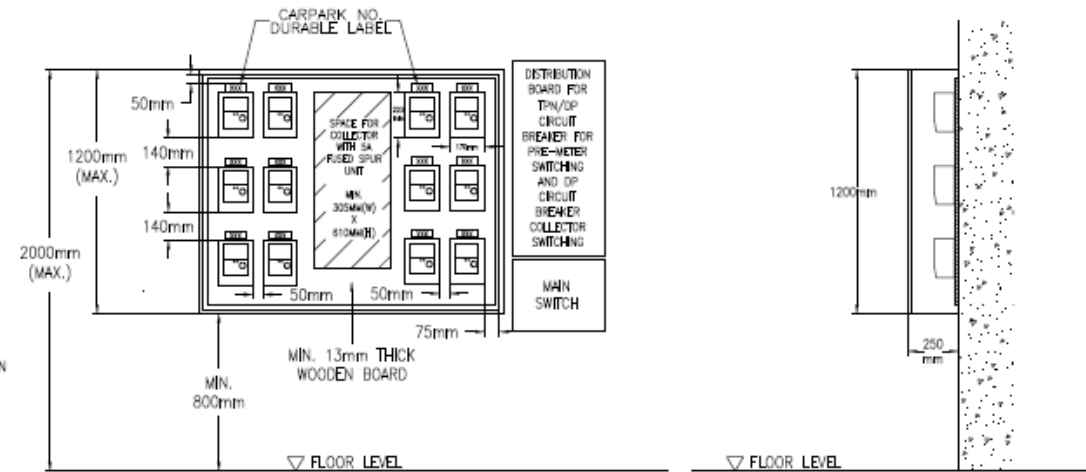

INTERNAL VIEW

SIDE VIEW

Meter Cubicle shall be made of stainless steel of minimum thickness 3mm.

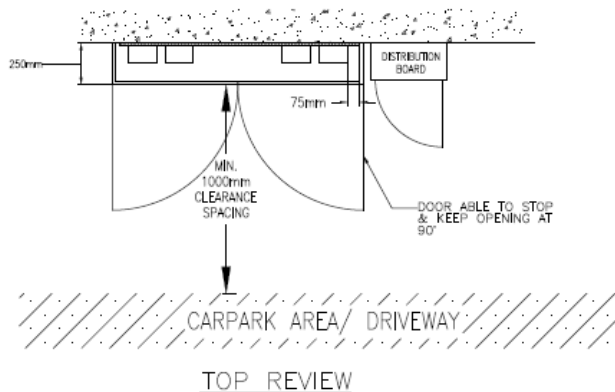

Facilities Locations & Wooden Board Requirements

A minimum 610mm(H) x 305mm(W) x 13mm(thick) wooden board, with front clearance of minimum 900mm, shall be provided for mounting CLP collector(s) in the **meter cubicle(s)**.

Beside of collector wooden board, a single phase fused connection unit for CLP collector shall be provided (fuse rated at 5A, unless otherwise specified). The circuit should be protected by a dedicated double poles MCCB if applicable of rating not less than 20A tapped off from un-metered distribution board in the same room/cubicle. Suitable neutral and earthing terminals should be provided in fused connection unit for CLP collector. The tapped off power supply location should be submitted to CLP Power for consent prior to the installation.

The location of the meters and collector is required to be able to receive strong telecommunication signal (e.g. 3G/4G)

Detail "B" – Separate Wall-mounted Meter Cubicle Option for existing building

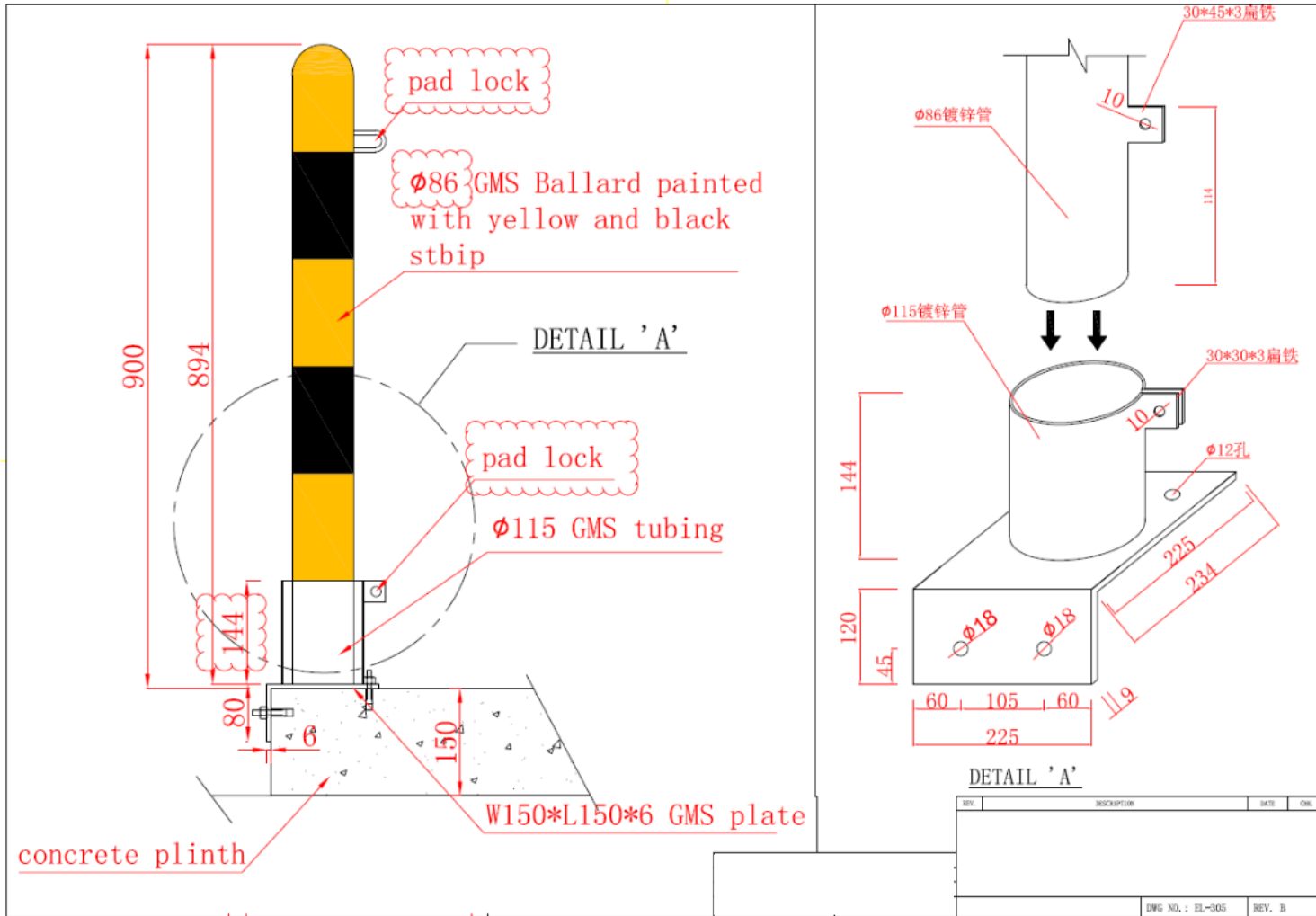

Detail "B" – Separate Wall-mounted Meter Cubicle Option for existing building

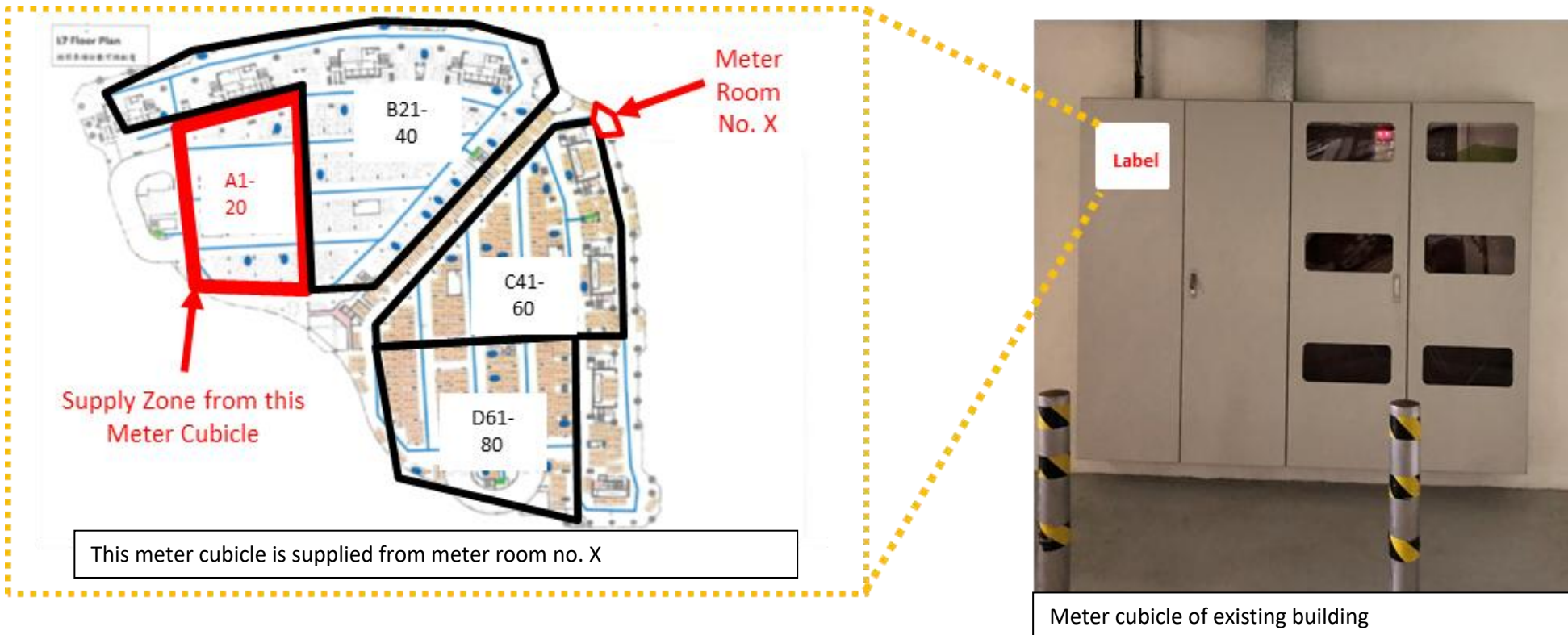
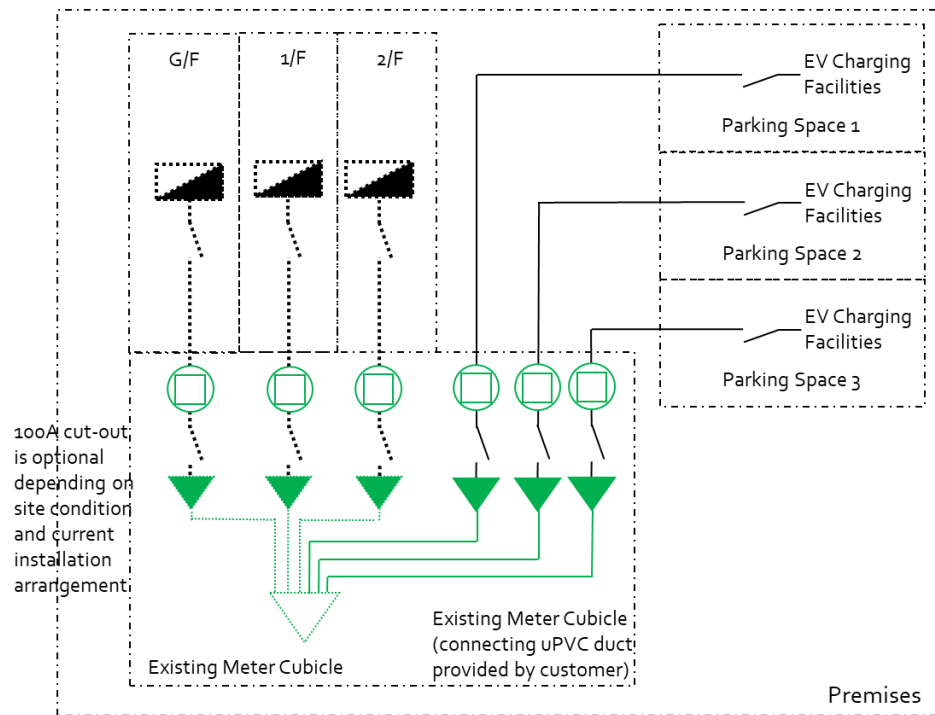
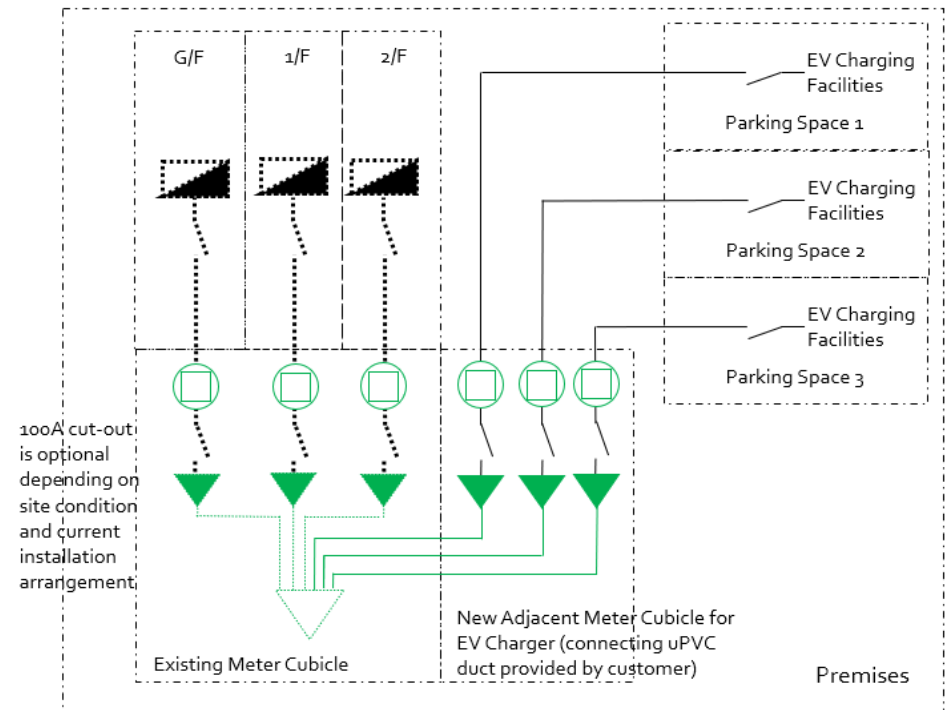

Fig. 4 – Example of EV Charging Facilities Supply Zone Layout



Separate supply and meters for EV charger to be installed inside the concrete meter cubicle of residential revenue meters



Separate supply and meters for EV charger to be installed inside the new adjacent meter cubicle at the location with prior CLP's agreement

Fig. 5 – Typical Supply and Metering Arrangement for Village House / Detached House (applicable to existing / new house design)