



**Standard Metering Arrangement for Electric Vehicle
(EV) Charging Facilities
for
Car Parks of New Building Development**

CLP POWER HONG KONG LIMITED

DATE: November 2016

**Standard Metering Arrangement of
Electric Vehicle (EV) Charging Facilities for
Car Parks of New Building Developments**

1. Scope

The Guideline is intended to provide general technical references for standard metering arrangement to enable a developer / customer / contractor in the design of electrical installation for Electric Vehicle (EV) Charging Facilities to comply with CLP requirements only. It is the responsibility of the designer to ensure that the design complies in all respect with Electricity Ordinance (1990) and other statutory requirements.

The Guideline should be read in conjunction with CLP Supply Rules, CLP Guide to Supply and Metering Arrangement on Customer's Internal Distribution System, Code of Practice for the Electricity (Wiring) Regulations, Technical Guidelines on Charging Facilities for Electric Vehicles (EV) Charging-enabling for Car Parks of New Building Developments published by the Electrical and Mechanical Services Department and Environmental Protection Department.

2. General Requirements

- 2.1. EV Charging Facilities shall mean (a) fixed electrical installations on the customer side including, but not limited to, switchboards, distribution boards, cabling, conduits and trunkings, and charging sockets / fixed electric chargers.
- 2.2. EV Charging Facilities shall be supplied and metered appropriately as per CLP's requirement.
- 2.3. Metering arrangement for EV Charging Facilities shall be complied to the requirements stated in "[Guide to Supply and Metering Arrangement on Customer's Internal Distribution System](#)" which is available at CLP website (www.clponline.com.hk).

3. Metering Arrangement

- 3.1. Individual metering shall be adopted for each private parking space with EV Charging Facilities owned by individual customer (Fig. 1).
- 3.2. A single metering arrangement shall be adopted for a group of visitor's parking spaces with EV Charging Facilities (Fig. 1).
- 3.3. Under normal circumstance, sub-meter arrangement shall not be adopted for new building development.

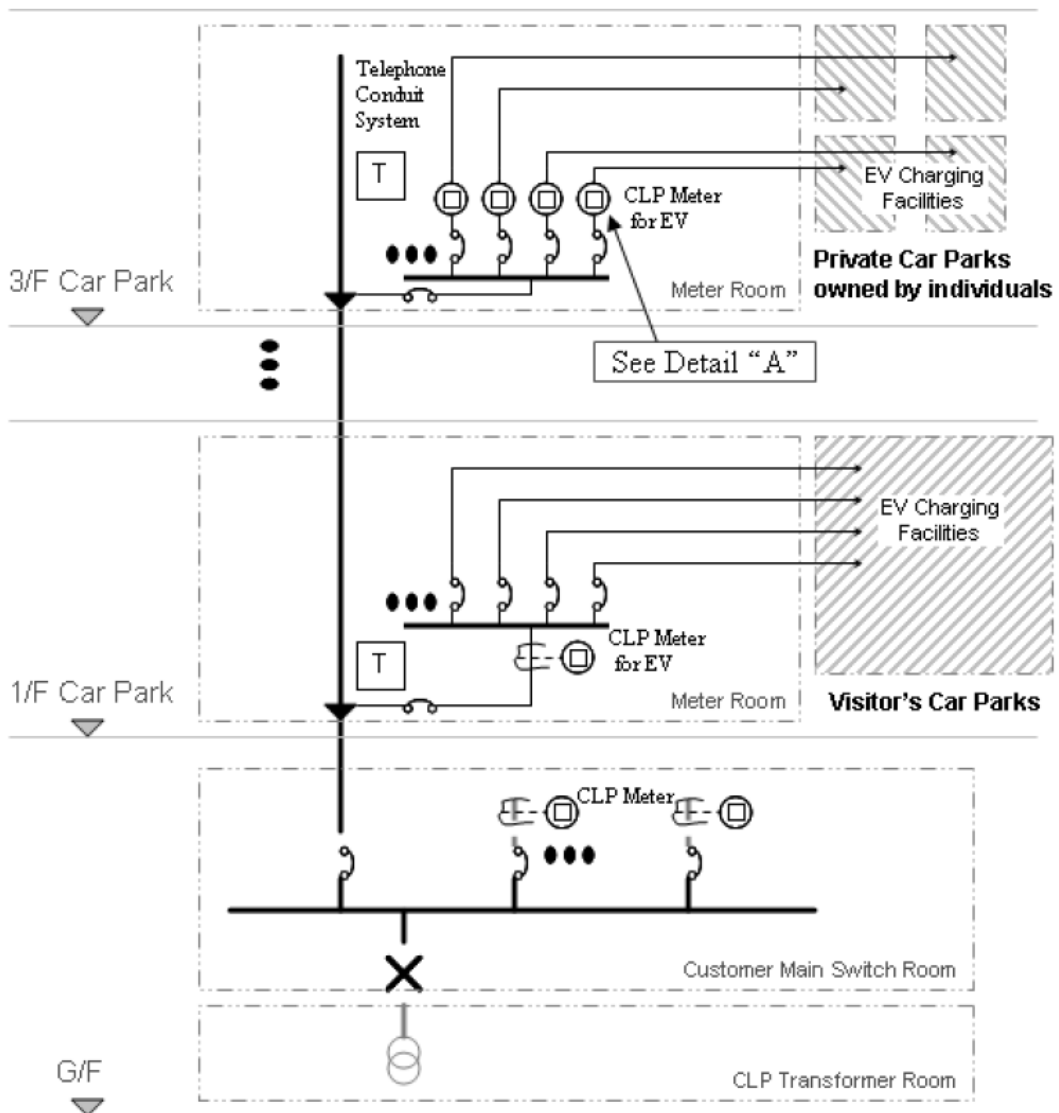

Fig. 1